



# IRIS 2



## DESCRIPTION

The IRIS 2 is a premium solution for public and residential street lighting, ensuring top-quality with all necessary EU certifications. Featuring high-efficiency LEDs and 41 optic options, it provides precise illumination. With a robust aluminum housing, corrosion resistance class C4 (C5 additional) and a lifetime of up to 100,000 hours (L95 B10), IRIS 2 ensures long-lasting performance even in harsh environments. Its tool-free opening allows quick and cost-effective maintenance, while power options from 120 W to 200 W offer adaptability for diverse applications. Ideal for creating energy-efficient, eco-friendly, visually comfortable lighting.

## APPLICATIONS

IRIS 2 is ideal for a wide range of outdoor applications: streets, highway roads, parking lots, railway platforms, pedestrian areas, parks and bike paths, also for urban infrastructure or recreational spaces.

## BENEFITS

- **Best in Class:** Designed, developed and manufactured by ENIM, a trusted EU producer.
- **Certified Quality:** CE, CB, ENEC, ENEC+, RoHS, EPD certifications ensuring compliance with all EU road requirements.
- **Superior Efficiency:** Advanced technology with high-efficiency LEDs for maximum performance.
- **Versatile Power Options:** Ranges from 120 W to 200 W, tailored to fit any lighting project.
- **Adaptable Optics:** 41 optic types ensure precise lighting for diverse applications.
- **Unique Design:** Sleek, dirt-resistant design perfected over 15 years for practicality and aesthetics.
- **Engineered for Longevity:** Built to last 100,000 hours (L95 B10).
- **Corrosion Resistance:** Corrosion resistance class C4 (C5 additional), ensuring durability in harsh environments.
- **Easy Maintenance:** Tool-less access simplifies installation and upkeep.
- **Safety First:** Integrated safety knife-switch prevents electric shocks.
- **SMART savings:** time dimming profiles DDF's for even more energy reduction.
- **Sustainability:** EPD certificate ensures low carbon emissions and eco-friendly materials.
- **Dark Sky Certified:** Reduces light pollution, preserving the beauty of the natural night sky.

\*Dark Sky applies to luminaires up to 3000 K.



## TECHNICAL INFORMATION:

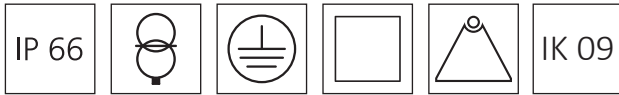

<b>ELECTRICAL</b>	<b>V</b>	Input voltage	220-240 (VAC)
	<b>Hz</b>	Rated voltage	50-60 Hz
	<b>W</b>	Luminaire wattage	120-200
	<b>Cosp</b>	Power factor	≥ 0.95
<b>OPTICAL</b>	<b>Lm</b>	Luminous flux	18000-32800
	<b>Lm/W</b>	Luminous efficacy	138-177 Lm/W
	<b>K</b>	Color temperature	2700/3000/4000 and 5700 for pedestrian crossing
	<b>Tg</b>	Performance temperature	25 °C
	<b>C°</b>	Ambient temperature range	-40 °C ≤ Ta ≤ +50 °C
	<b>CRI</b>	Color rendering index	≥70

Number of LED's	64					48				
<b>Power</b>	120	130	140	150	160	170	180	190	200	
<b>Luminous Flux, Lm</b>	18000-21240	19240-22750	20440-24220	21600-25650	23040-27680	24310-28730	25380-30060	26600-31540	27600-32800	
<b>Efficacy, Lm/W</b>	150-177	148-175	146-173	144-171	144-173	143-169	141-167	140-166	138-164	

Chromatic tolerance ( original MacAdam)	Not higher than 5
Life expectancy L/B	L95 B10 by 100000 hrs (Ta = 25 °C)

<b>HOUSING</b>	<b>Size</b>	608 x 295,4 x 95,6 mm
	<b>Weight</b>	max 7,5 kg
	<b>Body material</b>	Heat sink: cast aluminium, painted
	<b>Tool-less</b>	Lid opening and driver change
	<b>Protection against fogging</b>	The luminaire design incorporates a pressure-equalizing moisture/dust filter that prevents moisture condensation in the luminaire housing
	<b>Installation</b>	Adjustable bracket: angle - 20 + 25, Ø 60-76 mm, Ø 42-60 mm

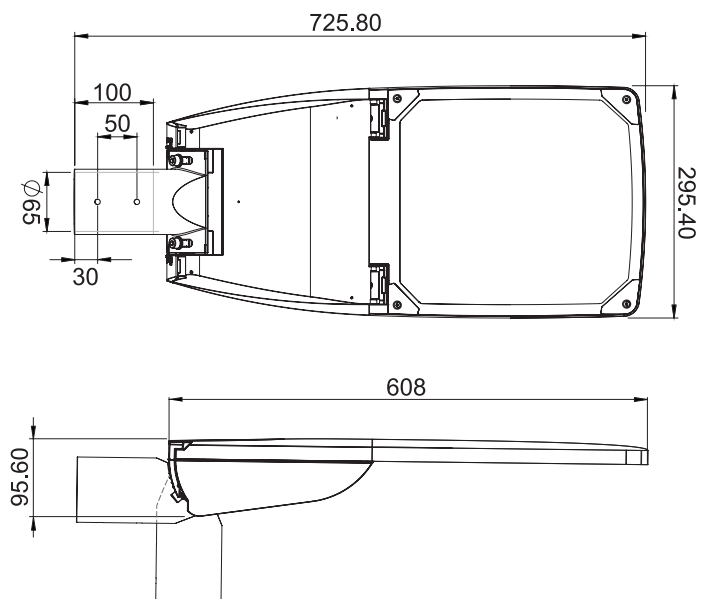

<b>OPTICS</b>	<b>Optical cover</b>	Glass, thermally hardened, 4 mm
	<b>Light source</b>	OSRAM/LUMILEDS
	<b>Optics</b>	Asymmetric optics lens
	<b>Optics type</b>	Very carefully selected optics suppliers, the optics are transparent to ensure minimal light loss
	<b>Maintenance</b>	Optical module sealed for life. No internal cleaning required
<b>Protection against light pollution</b>		0 candela light emission above 90°

<b>DRIVER</b>	<b>Input voltage</b>	Input 180-264 VAC, 100-305 VAC, 176-280 VDC (depending on the driver in use)
	<b>Intelligent temperature Guard (ITG)</b>	The intelligent temperature guard protects the LED driver from thermal overheating by reducing the output power or switching off in case of operation above the thermal limits of the luminaire or ballast
	<b>External temperature management (ETM + NTC)</b>	ETM protects the LED module against thermal overstress. An external temperature sensor (NTC) detects the LED module temperature and the LED driver will limit the output current according to this temperature
	<b>Overvoltage with a variable surge protection</b>	N/L - 10kV, P/(N/L) - 10kV
<b>Interfaces</b>		one4all (DALI, DALI2, DT 6, DSI, switchDIM, corridorFUNCTION) - near field communication (NFC) - ready2mains (configuration and dimming via mains) - U6Me2 (configuration of chronoSTEP 2 via mains time dimming function), midnight dimming profiles

<b>OPTIONAL</b>	<b>Sockets</b> for different various smart control sensors D4I ZHAGA TOP-BOTTOM / D4I ZHAGA BOTTOM / D4I ZHAGA TOP / NEMA TOP
-----------------	--

<b>REMARKS</b>	CLO	The light output of an LED module reduces over the course of its lifetime. The Constant Light Output (eCLO) function compensates for this natural decline by constantly increasing the output current of the LED driver throughout its lifetime
	Power factor ((Cosφ)	≥ 0.95
	Recommended mounting height	6-15 m
	Luminaires are ready to install	

#### LOGISTIC DETAILS:

Full pallet size/cm L*W*H	Number of luminaires per row	Number of rows	QTY per pallet/pcs
125 X 80 X 120	4	7	28
<b>Volume per pallet</b>		<b>Kg per pallet</b>	
0,8816 m <sup>3</sup>		<b>Netto</b>	<b>Brutto</b>
		196	221

